

HW 6-6: VOLUME

Find the volume of each prism. Show your calculations and round to the nearest tenth when necessary. Don't forget your units! (FOR CREDIT, SHOW WORK ON ALL QUESTIONS)

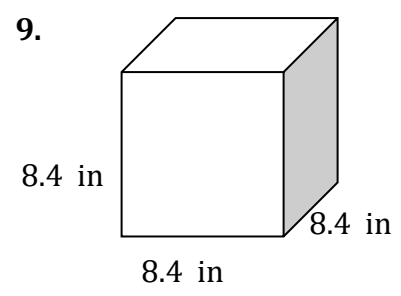
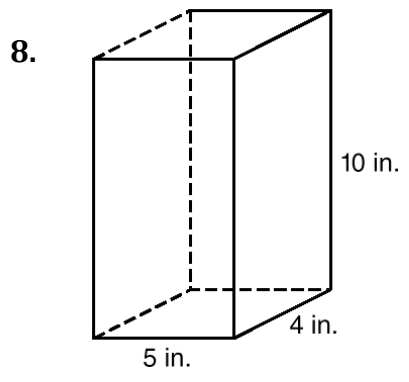
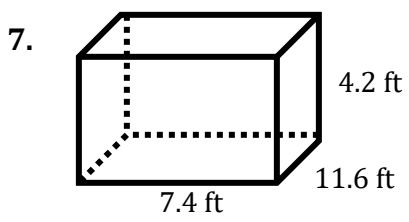
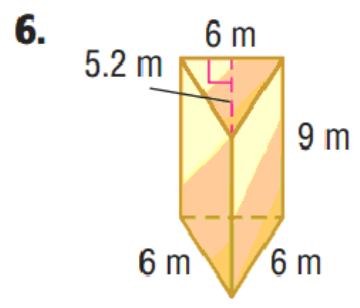
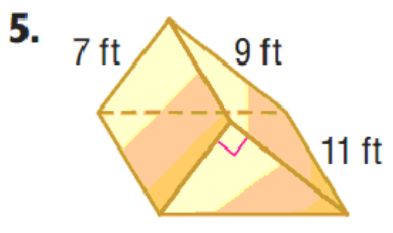
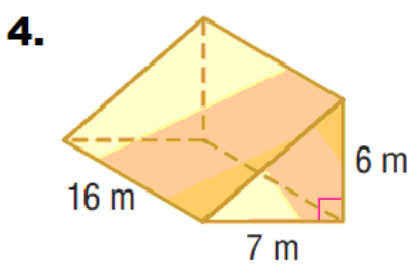
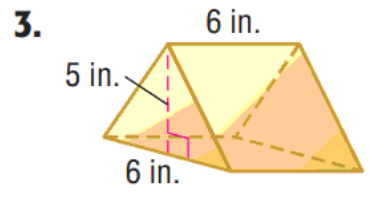
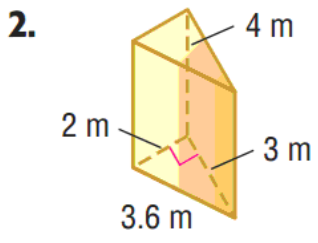
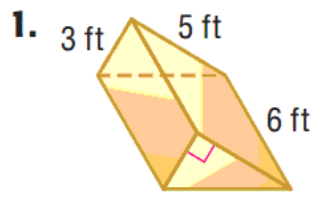

10. Find the volume of a rectangular prism with a length of 30 meters, a width of 11.5 meters, and a height of 8 meters.

11. Find the volume of a cube with a side length of 15 feet.

12. The length of the front of the building shown is 112 feet. The width of the building is 185 feet, and the height of the building is 305 feet. What is the volume of the building?



13. Find the volume of the triangular prism shown.

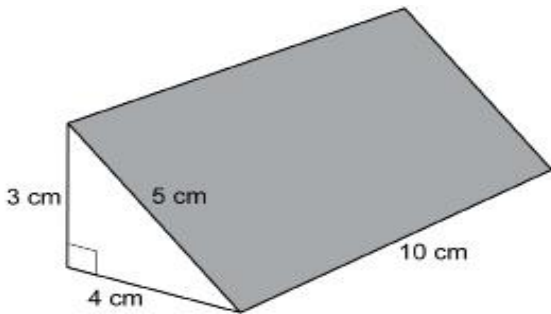

For #14 and #15, draw and label two different rectangular prisms that both have a volume of 800 cubic inches.

14.

15.

16. Draw and label a triangular prism whose base is a right triangle and that has a volume of 500 cubic feet.

17. The prism shown below has a length of 25 in., a height of 9 in., and a volume of 1800 cubic inches. What would the width of this prism be?

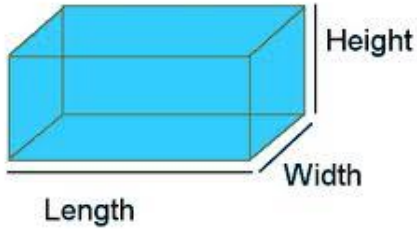

Rectangular prism

18. The triangular prism below has a length of 20 cm and the height of 4 cm. If the total volume of the prism is 500 cubic centimeters, how long is the base of the prism? (That's the part labeled 'b' on the diagram).

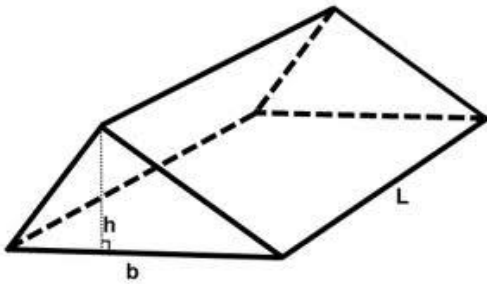

19. An aquarium filled with water measures 30 inches by 12 inches on the bottom and has a height of 15 inches. You have a solid cube that measures 5 inches on each side. If you were to drop the cube into the aquarium, what would the volume be of the water remaining in the aquarium?